



Oil/Air- Cooling Systems

AKG-Range
T1 - T11



T e c h n i c a l Specification



Your innovative partner to design and supply engineered cooling packages



General

Our T range is designed to help you find an individual solution for your cooling application.

Our cooling systems offer a wide variety of products which have been fully tried and tested even under the most arduous working conditions.

A range of 11 basic types covers almost all cooling applications involving a large variety of fluids in stationary and mobile machines.

AKG and its representatives as experts in the field of cooling systems will be delighted to assist you.

As part of our ongoing technical improvements, AKG maintains the right to introduce modifications to the specifications in this brochure.

Your partner for

Features

- High efficiency cooling systems made from Aluminium
- High performance and working pressure - even for heavy duty hydraulic and lubrication applications
- Maximum working pressure
T1 - T8 26 bar
T9 - T11 10 bar
- Offering high flexibility for usage with transmission, engine, hydraulic and lubrication oils
May be also used as off-line coolers
- Cooling systems can be fitted with 12V/24V DC, 3 phase or hydraulic motors

Benefits

- **Short lead times**
- **Cost effective**
- **Cooling systems fully equipped for immediate use**
- **Spares from stock**
- **Robust design, tried and tested for many years**
- **Maintenance free**
- **Low noise levels**

Applications

The units can be used for cooling: mineral oil, synthetic oil, bio oil, HFA B C D liquids, water/glycol mixture, containing 50 % antifreeze and corrosion inhibitors

Function: Heat will be transferred from the fluid to the cooling air flow

Options

- Temperature regulator
- Off-line cooler packages with integral pump
- 60 Hz electric motors
- Pusher fans (standard equipment is puller fans)

Oil/Air-Cooling Systems

AKG-Range
T1 - T11

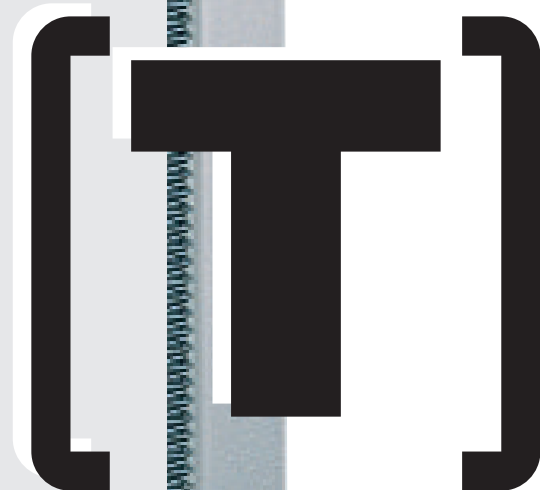

Please note:

- **Set up and operating instructions**
- **General Terms of Sales and Delivery**
- **Spares list**

Technical Data

T1 - T8

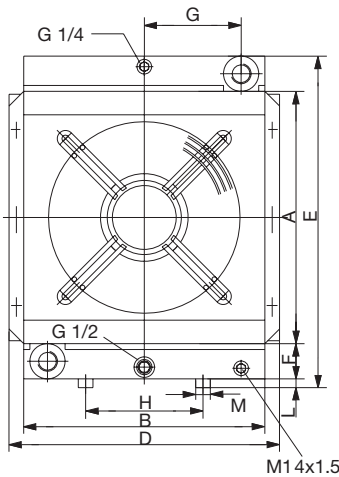

T9 - T11

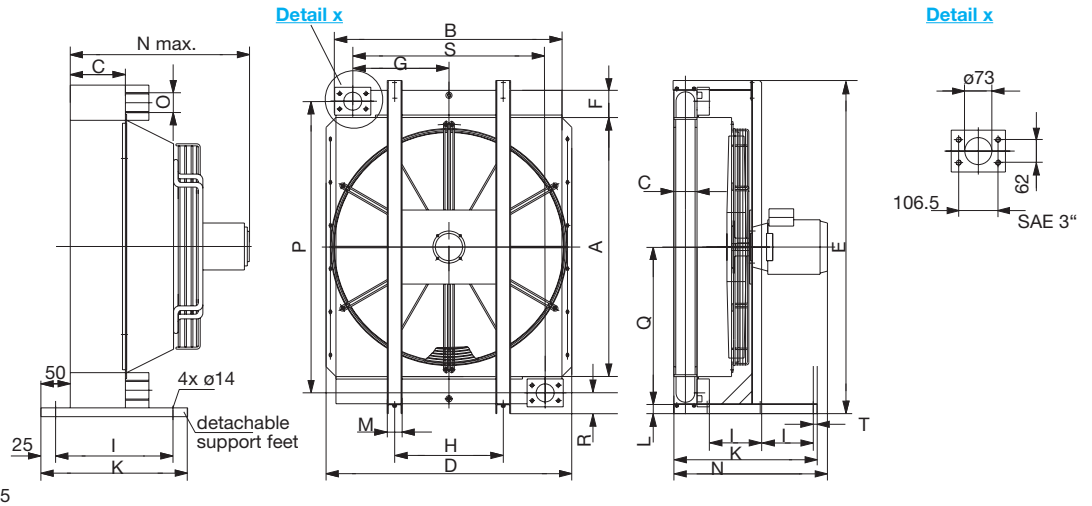

SPECIFICATION

Cooler Type	T1	T2	T3	T4	T5 (T5K) ²⁾	T6	T7	T8	T9	T10	T11
Heat rejection ¹⁾	1-5	3-10	8-15	10-20	15-25	20-35	25-40	35-75	60-120	85-180	120-260

DIMENSIONS

A	200	300	400	400	550	650	800	800	1050	1200	
B	191	302	396	396	411	557	557	651	915	1206	
C	63	63	63	94	94 (63)	94	94	140	94	113	140
D	248	355	451	451	466	607	608	722	995	1276	
E	315	415	515	535	690	790	940	960	1352	1520	
F	50	50	50	60	60	60	60	70	110	110	
G	65	115	160	160	165	235	235	280	390	532	
H	80	150	200	200	200	310	310	400	440	525	
I	150	200	200	250	250	250	250	250	215	210	
K	200	250	250	300	300	300	300	300	580	750	
L	15	15	15	15	20	20	20	20	40	50	
M	25	25	25	25	30	50	50	50	65	100	
N max.	175	370	400	430	440 (410)	ca. 450	ca. 450	ca. 590	ca. 650	ca. 790	ca. 900
O	1" BSP	1" BSP	1" BSP	1 1/4" BSP	1 1/4" BSP (1" BSP)	1 1/4" BSP	1 1/4" BSP	1 1/2" BSP			
P									1182	1332	
Q									635	710	
R									91	94	
S									780	1064	
T									15	20	

(all dimensions in mm)

ORDER CODE SYSTEM

52 . 2 . 0000

Cooler type: e. g. 04 = T4

Direction of cooling air flow: pulling = 2 (standard)

pushing = 1 (available for 3 phase and hydraulic motors)

01 = 12 V DC
 02 = 24 V DC
 03 = 3 phase electric motor
 04 = hydraulic motor
 23 = low noise version with 3 phase electric motor

1) For details use diagrams and tables as appropriate

2) use T5K for low oil flows

All systems are pressure tested according to DIN 50104

Cooler Type	Order Number	Fan Diameter [mm]	Fan Speed [rpm]	Noise Level [dB(A), 1m]	Motor Voltage [V]	Power Consumption [kW]	Volume [l]	Working Pressure [bar]	Total Weight excluding fluid [kg]	
T1	5200.201.0000	167	3250	71	12	0.08	1.0	26	6.7	
	5200.202.0000	167	3250	71	24	0.08	1.0	26	6.7	
	5200.203.0000	170	2750	64	230/400	0.05	1.0	26	7.1	
T2	5202.201.0000	255	2600	74	12	0.15	1.9	26	15.6	
	5202.202.0000	255	2600	72	24	0.15	1.9	26	15.6	
	5202.203.0000	250	3000	75	230/400	0.25	1.9	26	15.6	
	5202.204.0000	250	3000	75	Hydraulic		1.9	26	15.6	
L	5202.223.0000	250	1500	57	230/400	0.18	1.9	26	15.6	
T3	5203.201.0000	350	2950	76	12	0.2	2.9	26	23	
	5203.202.0000	350	2950	78	24	0.25	2.9	26	23	
	5203.203.0000	380	1500	75	230/400	0.37	2.9	26	23	
	5203.204.0000	380	1500	75	Hydraulic		2.9	26	23	
L	5203.223.0000	380	1000	68	230/400	0.25	2.9	26	23	
T4	5204.201.0000	350	2950	77	12	0.2	5.2	26	28.8	
	5204.202.0000	350	2950	78	24	0.25	5.2	26	28.8	
	5204.203.0000	380	1500	77	230/400	0.37	5.2	26	28.8	
	5204.204.0000	380	1500	77	Hydraulic		5.2	26	28.8	
L	5204.223.0000	380	1000	68	230/400	0.25	5.2	26	28.8	
T5	5205.201.0000	385	3100	79	12	0.27	6.3	26	38	
	5205.202.0000	385	3100	79	24	0.24	6.3	26	38	
	5205.203.0000	450	1500	77	230/400	0.37	6.3	26	38	
	5205.204.0000	450	1500	77	Hydraulic		6.3	26	38	
	L	5205.223.0000	450	1000	68	230/400	0.25	6.3	26	38
K	5215.203.0000	450	1500	77	230/400	0.37	6.3	26	38	
T6	5206.202.0000	2 x 305	3100	81	24	2 x 0.27	9.4	26	49	
	5206.203.0000	500	1500	79	230/400	0.55	9.4	26	49	
	5206.204.0000	500	1500	79	Hydraulic		9.4	26	49	
	L	5206.223.0000	500	1000	68	230/400	0.37	9.4	26	49
T7	5207.203.0000	500	1500	79	230/400	0.55	10.6	26	54	
	5207.204.0000	500	1500	79	Hydraulic		10.6	26	54	
	L	5207.223.0000	500	1000	68	230/400	0.37	10.6	26	54
T8	5208.203.0000	630	1000	79	230/400	1.1	17.7	26	89	
	5208.204.0000	630	1000	79	Hydraulic		17.7	26	89	
	L	5208.223.0000	630	750	68	230/400	0.55	17.7	26	89
	S	5208.231.0000	630	1500	90	230/400	2.2	17.7	26	89
T9	5209.203.0000	900	1000	88	230/400	2.2	25	10	190	
	5209.204.0000	900	1000	88	Hydraulic		25	10	190	
	L	5209.223.0000	900	750	82	230/400	1.5	25	10	190
T10	5210.203.0000	900	1500	98	400/690	5.5	31	10	200	
	5210.204.0000	900	1500	98	Hydraulic		31	10	200	
	L	5210.223.0000	900	1000	88	230/400	3.0	31	10	200
T11	5211.203.0000	1000	1500	100	400/690	11.0	55	10	ca. 290	
	5211.204.0000	1000	1500	100	Hydraulic		55	10	ca. 290	
	L	5211.223.0000	1000	1000	90	400/690	7.5	55	10	ca. 290

3 phase electric motor: T2 - T9: B14, small flange, T10 - T11: B5
displacement [cm³] hydraulic motor: T2 - T8: 11 ccm, T9 - T10: 21 ccm

Materials

Cooler:

Aluminium

Fan blade:

Plastic

Fan shroud, finger guard, support feet, motor support flange:

Steel (Zinc plated), Painted/Powder coated

Easy sizing of T-coolers

The following tables may be used to quickly select a T-cooler.

The data is based on the assumption that oil inlet temperature does not exceed 70 °C for hydraulic and 110 °C for lubrication applications.

Please use the following heat rejection figures if no details are available:

- Agricultural and construction machinery: 1/3 of Diesel engine power
- Hydraulic pumps driven by an electric motor: 1/3 of electric motor power

Hydraulic applications

Heat rejection [kW @ 30 °C ambient temperature]													
Oil flow in l/min	T1	T2	T3	T4	T5K	T5	T6	T7	T8	T8S	T9	T10	T11
10	2	4	6										
20	3	6	8	8	15								
30	4	7	10	11	17								
50	5	8	12	13	18	21	28	32	39	46			
75	5.5	9	13	15	20	23	30	34	42	52	61		
100		10	14	16	21	24	32	36	44	56	69	112	
150			16	18	23	26	34	38	48	63	81	128	172
200						28	35	40	50	68	90	140	196
250									51	72	96	148	212
300											100	156	228
400											110	168	248
500											118	180	266
600													280

Heat rejection [kW @ 40 °C ambient temperature]													
Oil flow in l/min	T1	T2	T3	T4	T5K	T5	T6	T7	T8	T8S	T9	T10	T11
10	1.5	3	5										
20	2.5	4	6	6	11								
30	3	5	7	8.5	13								
50	3.5	6	9	10	14	16	20	24	28	34			
75		7	10	11	15	17	23	26	31	31	46	60	
100		8	11	12	16	18	24	27	33	42	52	84	
150			12	13	17	20	25	29	36	47	61	96	131
200						21	26	30	37	51	68	105	147
250									38	54	72	111	159
300											75	117	171
400											83	126	186
500											89	135	200
600													210

Easy sizing of T-coolers

For a more detailed and customised cooler selection exact temperatures and flows are necessary. Please select your cooler according to the example on page 10 or seek advice from AKG or its representatives.

Lubrication oil applications

Heat rejection [kW @ 30 °C ambient temperature]													
Oil flow in l/min	T1	T2	T3	T4	T5K	T5	T6	T7	T8	T8S	T 9	T 10	T 11
10	4	8	12										
20	6.5	11	16	16	30								
30	8	14	19	22	34	35							
50	9.5	17	23	26	37	42	55	64	78	93			
75	10.5	19	26	30	40	46	60	69	83	104	122		
100		21	28	32	42	49	64	72	88	112	138	224	
150			32	36	46	53	67	77	96	126	162	256	344
200						56	70	80	100	136	180	280	392
250									102	144	192	296	424
300											200	312	456
400											220	336	496
500											236	360	532
600													560

Heat rejection [kW @ 40 °C ambient temperature]													
Oil flow in l/min	T1	T2	T3	T4	T5K	T5	T6	T7	T8	T8S	T 9	T 10	T 11
10	3.5	7	11										
20	5.5	10	14	14	27								
30	7	12	17	20	30	31							
50	8	14	20	23	32	37	48	56	69	81			
75	9	16	22	27	35	40	53	60	73	91	107		
100		18	24	29	37	43	55	63	77	98	121	196	
150			28	32	40	46	59	67	84	110	142	224	301
200						49	62	70	88	119	158	245	343
250									90	126	168	259	371
300											175	273	399
400											193	294	434
500											207	315	466
600													490

Specific heat rejection T1 - T8

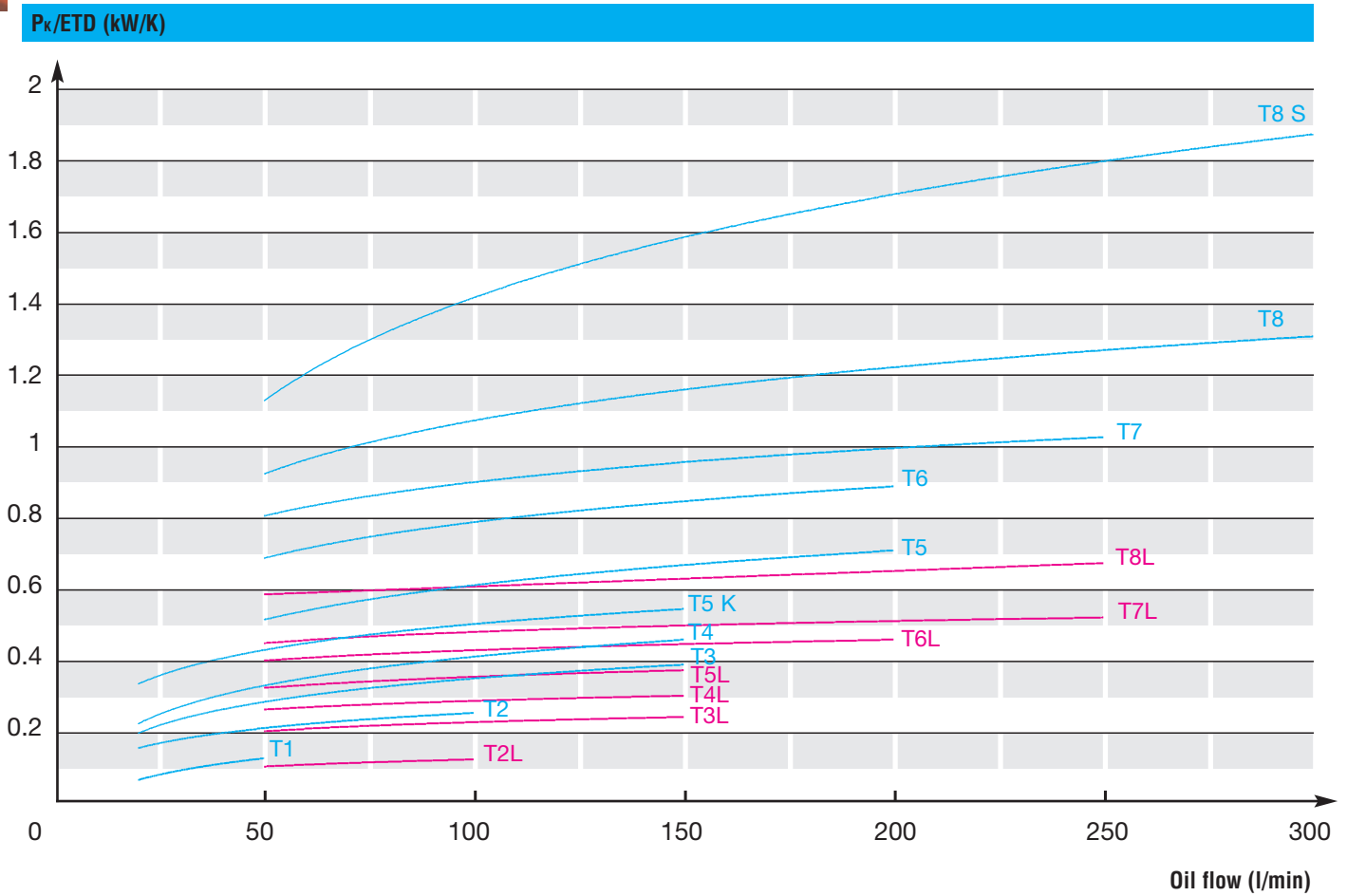

Pressure drop T1 - T8

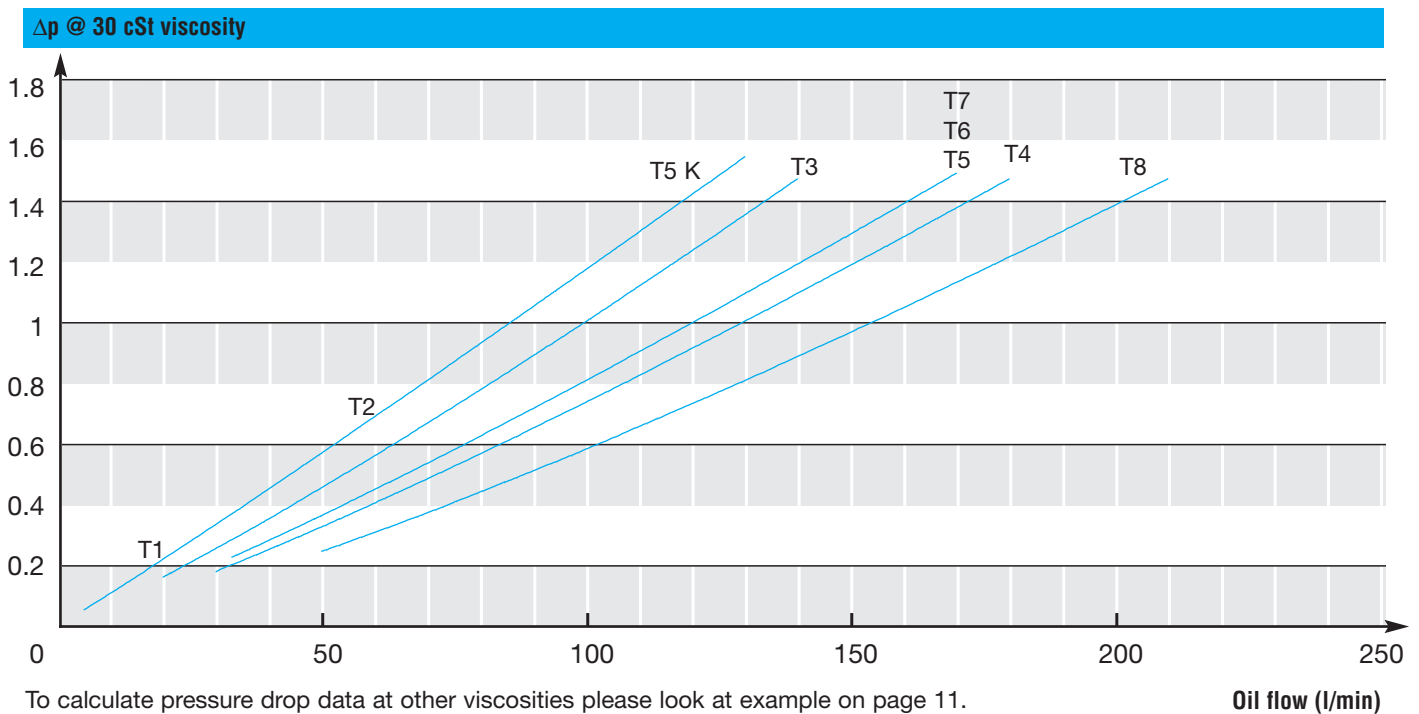

To calculate pressure drop data at other viscosities please look at example on page 11.

Specific heat rejection T9 - T11

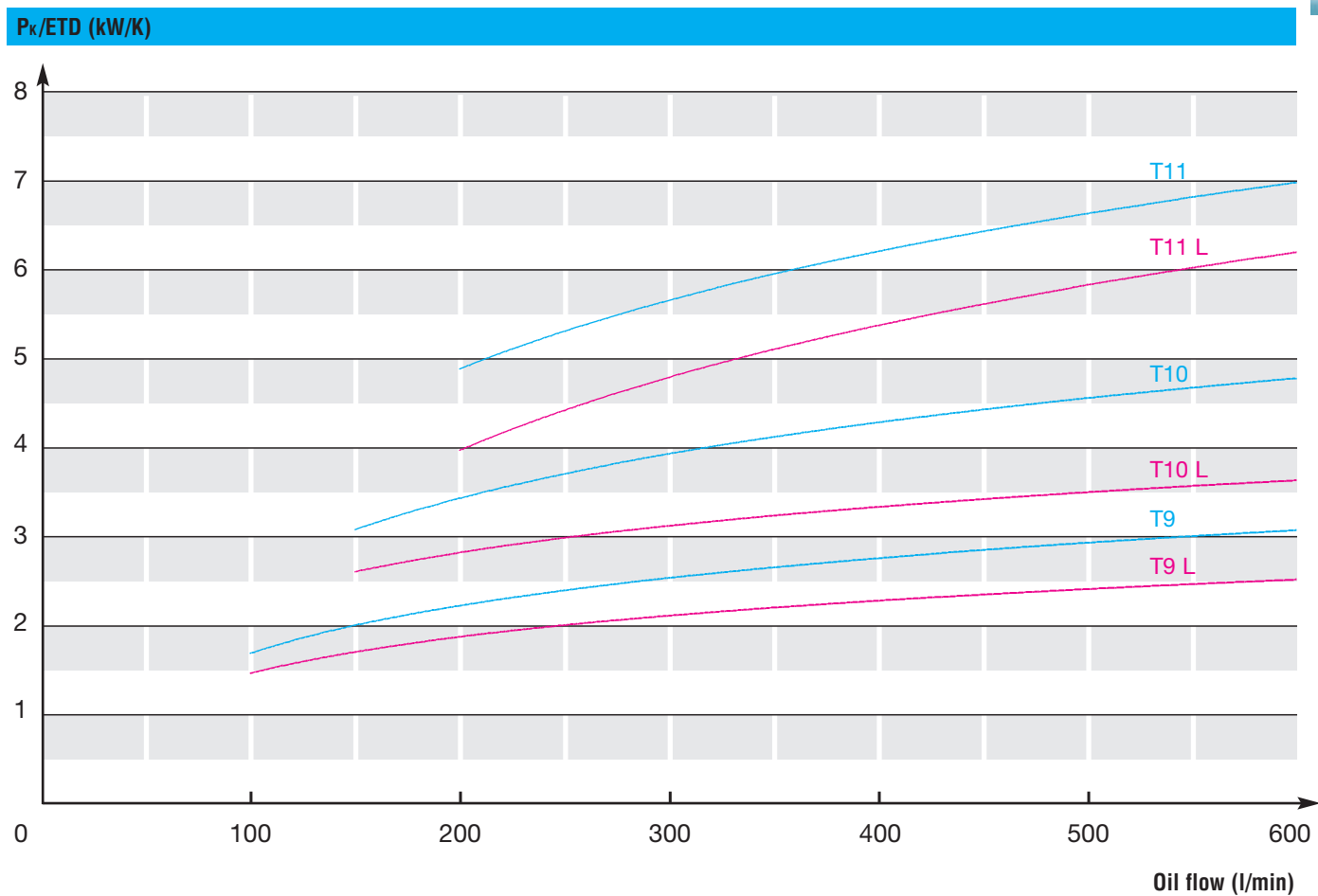

Pressure drop T9 - T11

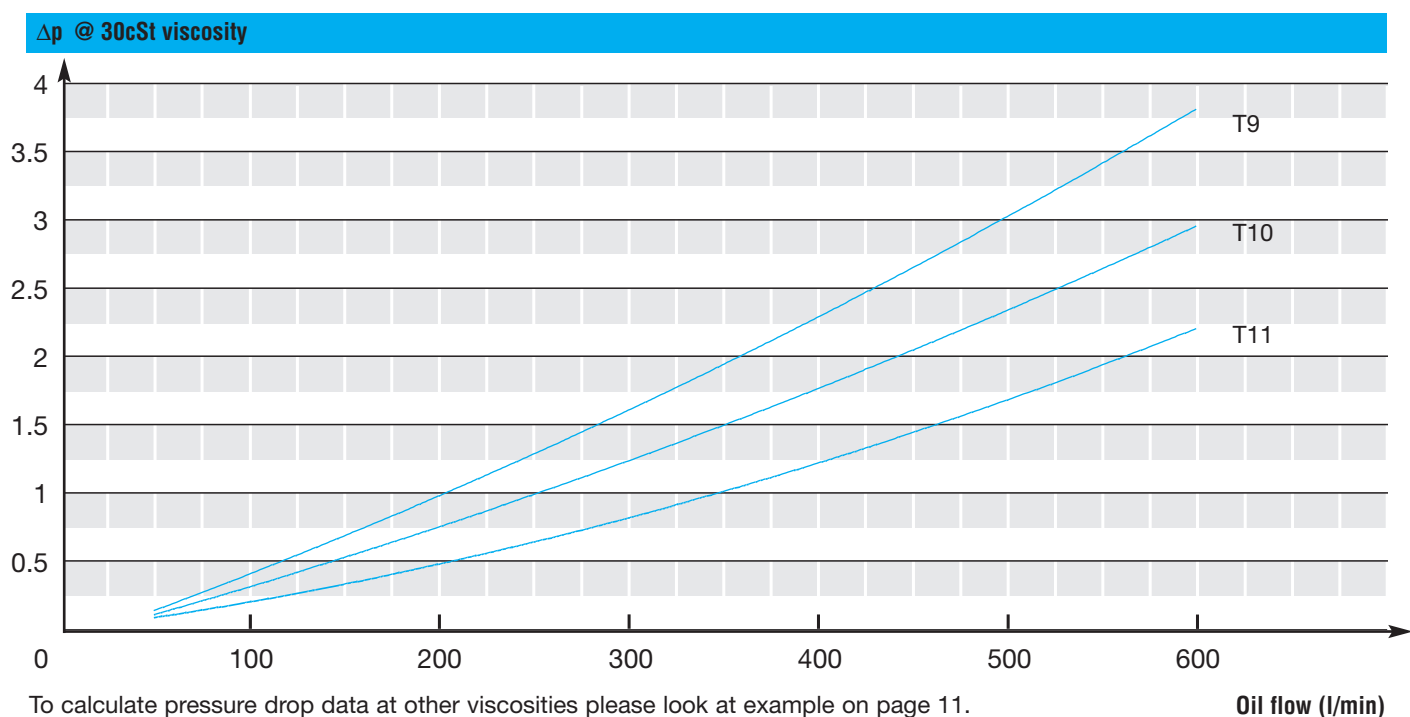

Selecting a cooling system

To select a cooler for your application, the following data is required:

- **Heat rejection:** Alternative terminology is dissipation
- **Oil flow:** Circulating oil flow determines the cooler size
- **Oil inlet temperature:** Temperature of the oil entering the cooler
- **Cooling air flow temperature:** Air temperature at cooler face before entering matrix

1. Determination of input data

P_{req} [kW]	Heat rejection
V_{oil} [l/min]	Oil flow
T_{oil} [°C]	Oil inlet temperature
T_{caf} [°C]	Cooling air flow temperature

Example

$P_{req} = 12$ kW
$V_{oil} = 50$ l/min
$T_{oil} = 70$ °C
$T_{caf} = 30$ °C

2. Specific heat rejection

ETD [K] = $T_{oil} - T_{caf}$	Entering Temperature Difference
P_{rshr} [kW/K] = P_{req}/ETD	required specific heat rejection

ETD [K] = $T_{oil} - T_{caf} \Rightarrow 70\text{ °C} - 30\text{ °C} = 40\text{ °C} (= 40\text{ K})$
$P_{rshr} = P_{req}/ETD \Rightarrow 12\text{ kW} / 40\text{ K} = 0.3\text{ kW/K}$

3. Select according to diagram

P_{shr}/ETD [kW/K]	actual specific heat rejection
$P = (P_{shr}/ETD) \times ETD$	actual heat rejection

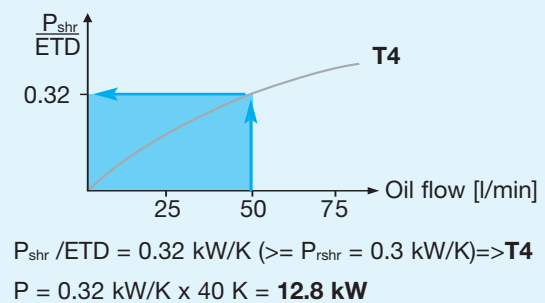

4. Pressure drop / Oil temperature difference

Obtain pressure drop @ 30 cST oil viscosity from diagram on page 8.
 To calculate for other oil viscosities please use example on page 11.

$$\Delta T_{oil} [\text{°C}] = 33 \times P[\text{kW}] / V_{oil}[\text{l/min}]$$

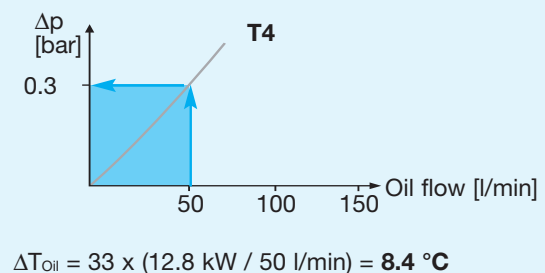

5. Results

**selected cooler T4: heat rejection 12.8 kW,
 oil temperature difference 8.4 °C,
 pressure drop 0.3 bar**

Conversion factors for different oil pressure drops

The pressure drop curves on pages 8 and 9 are based on a viscosity of $30 \text{ mm}^2/\text{s} = 30 \text{ cSt}$.
Please use conversion factor f to calculate pressure drop at other viscosities.

$\frac{\text{mm}^2}{\text{s}}, \text{ cSt}$	10	15	20	30	40	50	60	80	100
f	0.5	0.65	0.75	1.0	1.2	1.4	1.6	2.1	2.8

Example:

Pressure drop of type T7 is 1.3 bar @ 150 l/min and $30 \text{ mm}^2/\text{s}$.
Assume an oil type ISO VG 46 is used @ $60 \text{ }^\circ\text{C}$ having a viscosity of $20 \text{ mm}^2/\text{s}$.
To calculate new pressure drop multiply 1.3 bar by $f = 0.75$ to obtain the actual pressure drop 1 bar approximately.

Notes:



AKG Thermotechnik GmbH & Co. KG

Bookenburgweg 1
44319 Dortmund
Germany
Telefon: +49 231 - 921 55 0
Fax: +49 231 - 921 55 29
E-Mail: info@akg-group.com
Internet: www.akg-group.com



AKG – A STRONG GLOBALLY INTEGRATED GROUP OF COMPANIES

AKG is a globally leading supplier of high-performance coolers and heat exchangers as well as customised system solutions that comply with the highest quality standards.

Around the world 2,800 employees work at 12 manufacturing facilities located in Germany, France, Latvia, the USA, Brazil, China, Turkey and India. Together with a number of sales offices in additional countries and regions, AKG's cooling experts are on duty around the clock.

Longstanding partnerships with global OEM customers from 22 lines of business - including construction machinery, compressed air systems, agricultural and forestry machines, and many others - give fresh and innovative inspiration for AKG's line of pre-engineered cooling systems as well.

AKG operates one of the world's largest research, development, measurement and validation centres for cooling solutions and customized applications.

For 100 years, AKG's heat exchangers have stood for innovative solutions as well as the highest standard of engineering and manufacturing expertise.

Your AKG-Partner



AKG – A World Class Supplier

**Aluminium Coolers - Made by AKG
DIN EN ISO 9001**