

# HC62 miniBOOSTER

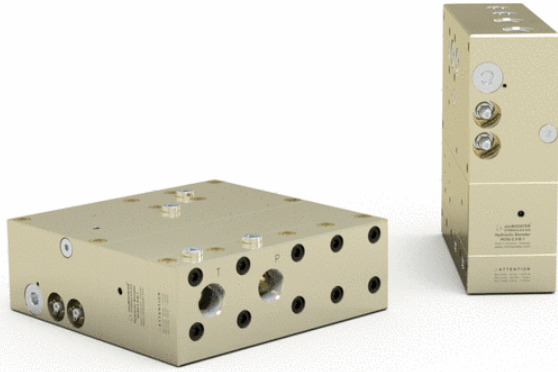

**HC62 versions:** 9 different intensification factors

**P<sub>IN</sub>:** 20 – 207 bar (inlet pressure)

**P<sub>H</sub>:** 800 bar maximum (outlet pressure)

**P<sub>RETURN</sub>:** As low as possible (return pressure to tank)

**P<sub>OUTLET</sub>:**  $P_H = (P_{IN} - P_{RETURN}) \cdot i$  (intensification)

**Mounting:** Inline tube / HP- flange mounting (optional)

**Accessories:** Pilot- operated dump valve available

**A model** = no dump valve

**B model** = with dump valve

**G model** = direct proportionally controlled

## Description

The HC62 is a high- flow unit which is capable of delivering up to 43 l/min flow on the high- pressure end. Like other miniBOOSTER models, the HC62 raises supplied pressure to a higher outlet pressure and automatically compensates for consumption of oil to maintain the high pressure. Adjustment of the outlet pressure is carried out by varying the supplied pressure. Relative to its flow capability, the HC62 is a compact unit weighing only 50.0 kg.

HP flange mounting is optional. Furthermore, it is possible to flange multiple HC62 boosters in order to achieve higher flow.

## Flow rates

Intensification factor <i>i</i>	Max. intensified outlet flow l/ min	Max. by- pass pump flow l/ min
1.2	43.0	150.0
1.5	37.0	150.0
2.0	32.0	150.0
2.5	26.0	150.0
3.3	22.0	150.0
4.0	18.0	150.0
4.9	14.0	150.0
6.3	11.0	150.0
8.2	9.0	150.0

## Dimensions

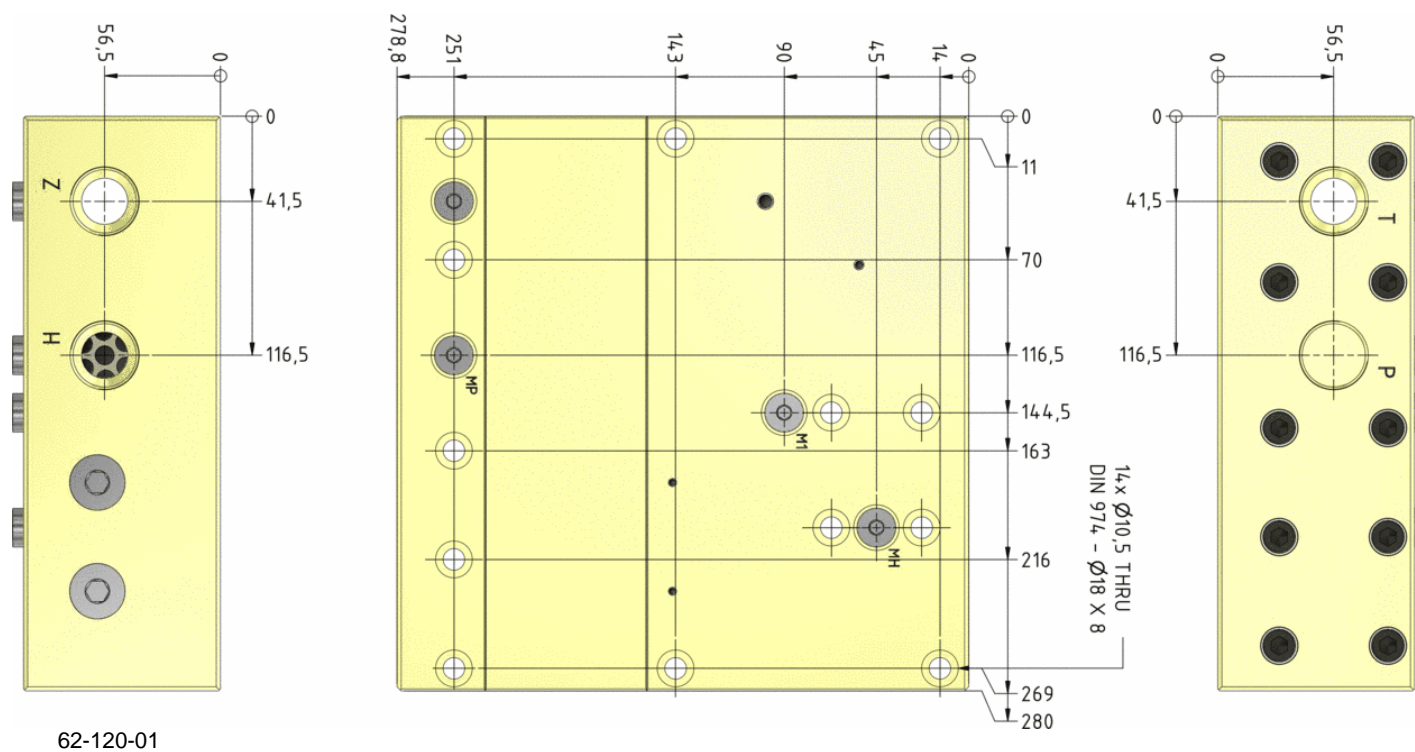

## Dimension drawings



Dimension drawing 62-120-01 and 62-120- F-00

## Functions

The basic operation is illustrated in the function diagram. Oil is fed through the directional valve CV to the IN port, flowing freely through the check valves KV1, KV2 and DV to the high- pressure side H. In this condition maximum flow through the booster is achieved giving a fast-forward function.

When pump pressure is reached on the high- pressure side H, the valves KV1, KV2 and DV will close. The end pressure will be achieved by the oscillating pump unit OP. The unit will automatically stall when end pressure on the high- pressure side H is reached. If a pressure drop on the high- pressure side exists due to consumption or leakage, the OP valve will automatically operate to maintain the end pressure.

## Function Diagram

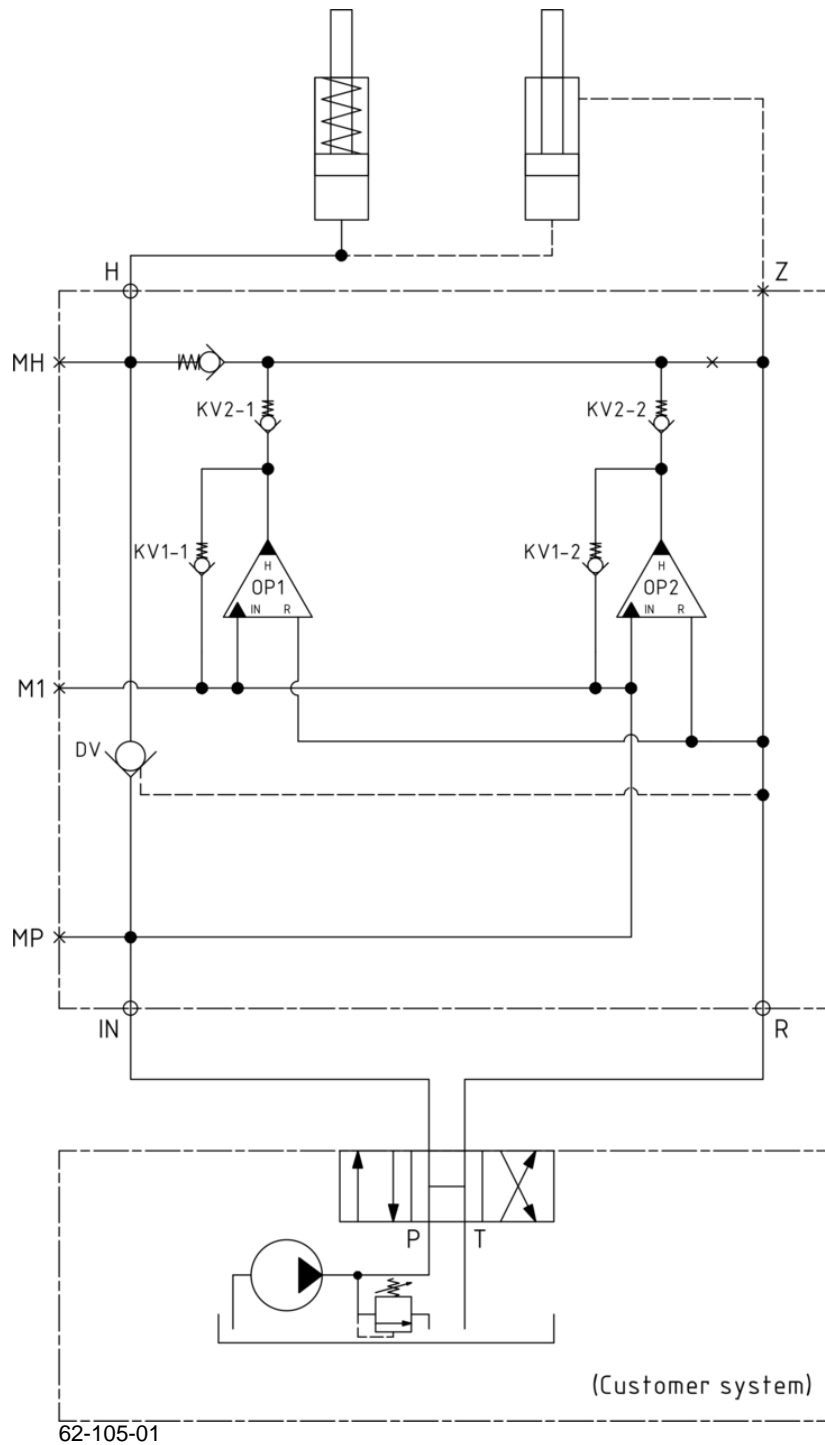

## Connection types

Connection	P / T	H / Z
1	1" BSPP	1" BSPP

## Max. tightening torque

	P / T	H / Z
	1" BSPP	1" BSPP
with steel washer	33.0 da/ Nm	33.0 da/ Nm
with aluminium washer	18.0 da/ Nm	–
with cutting edge	33.0 da/ Nm	33.0 da/ Nm

## Max. tightening torque flange mounting

Mounting bolt	
M10 8.8	5.0 da/ Nm

## Fluids and materials

Please see: General specifications

## Ordering an HC62

Ordering example of an HC62 with  $i = 4.0$ , DV incorporated and BSPP connections: HC62 - 4.0 - B - 1

<b>Model</b>	<b>Intensification, <math>i</math></b>	<b>Dump valve</b>	<b>Connections</b>
HC62	your selection...	your selection...	your selection...
	see flow rate table	A = (no) / A model	1
		B = (yes) / B model	
		G = (proportional) / G model	